



* Water & Air jet packages are not included in the base model of this bathtub

Slipper 73" x 42"

With over 21 5/8" in depth from the deck of the tub to the floor, the Slipper allows bathers to fully submerge themselves for a more pleasurable bathing experience. The Slipper can hold up to 50 gallons of water.

The Slipper is made from 100% acrylic with fibre-glass reinforcement for added strength and durability.

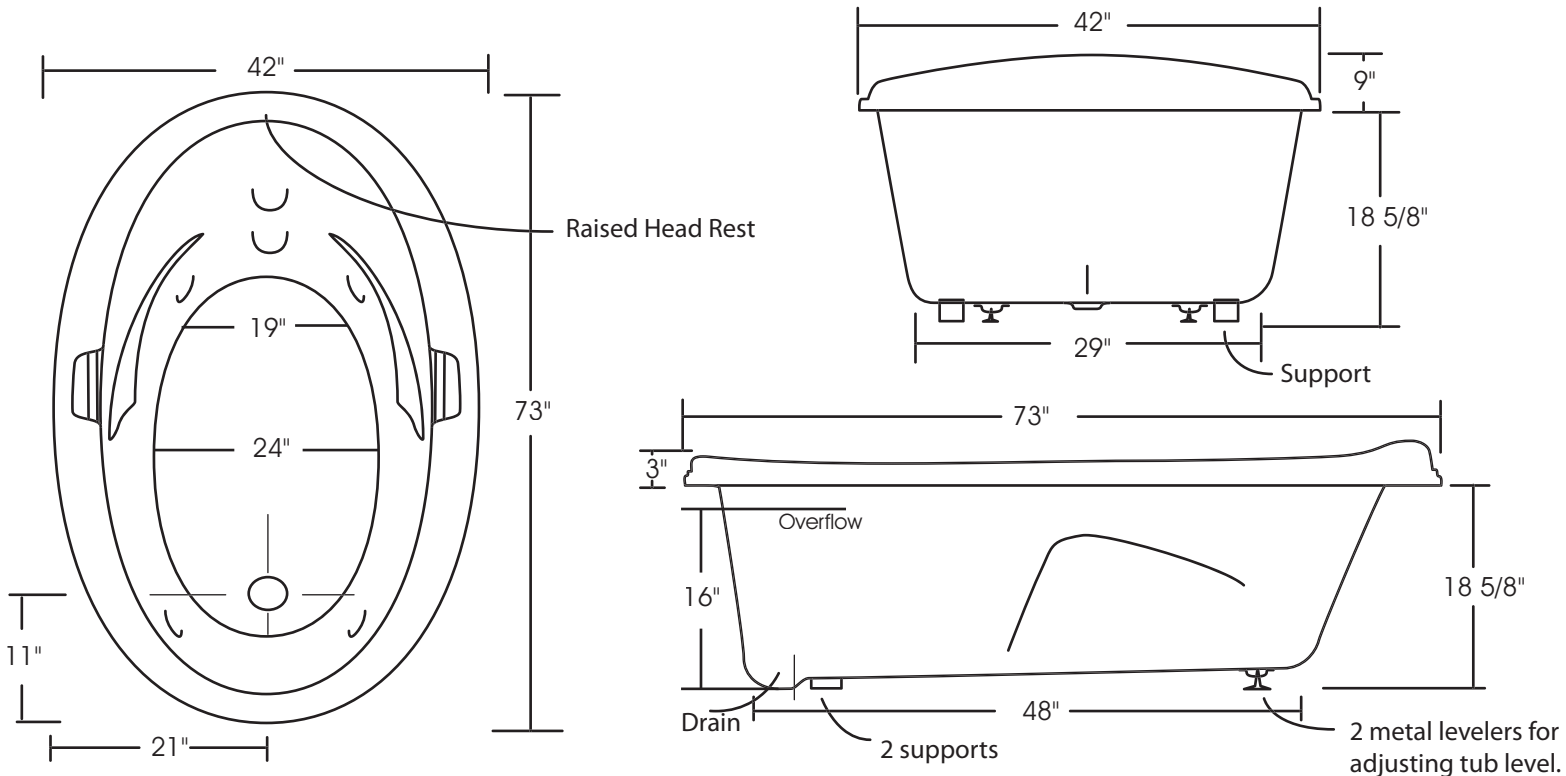

Drain: 2"
Overflow: 2 1/4"
Sizes: ± 3/8"
Diagram not to scale



This bathtub complies with CSA Standards

In keeping with our policy of continuing product improvement, Acri-Tec Industries Corp., reserves the right to change product specifications without notice.