



Independence 6026

Product # LH: 70011 | RH: 70021

59 ³/₄" x 26" x 37 ³/₄"

DESIGN FEATURES

- Inward swinging door, 18" wide opening
- Stainless steel grab bar
- Zinc-alloy, chrome plated door latch
- Textured bottom
- Dual drains internal 1 1/2". Drainage time: ~2 minutes
- Access panel
- Gel coat & fiber glass with stainless steel support frame
- Adjustable leveling feet
- Above floor rough in compatible (3")
- Water Capacity ~ 66 US Gallons
- Weight ~ 122 lbs
- Drain included.

AVAILABLE UPGRADES

- Chromotherapy
- Comfortwarm™
- Vibe Sound
- Aromatherapy

JETTING UPGRADES

LATERAL AIR

16 Jet Air System

- White 00021
- Brushed Nickel 00023
- Polished Chrome 00024

HYDROMASSAGE

6 Jet HydroMassage System

- White 00101
- Polished Chrome 00104

8 Jet HydroMassage System

- White 00111
- Polished Chrome 00114

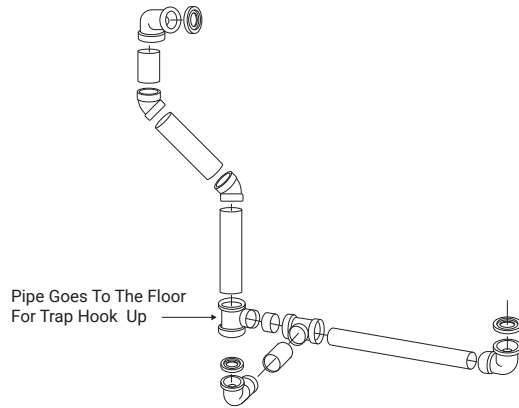
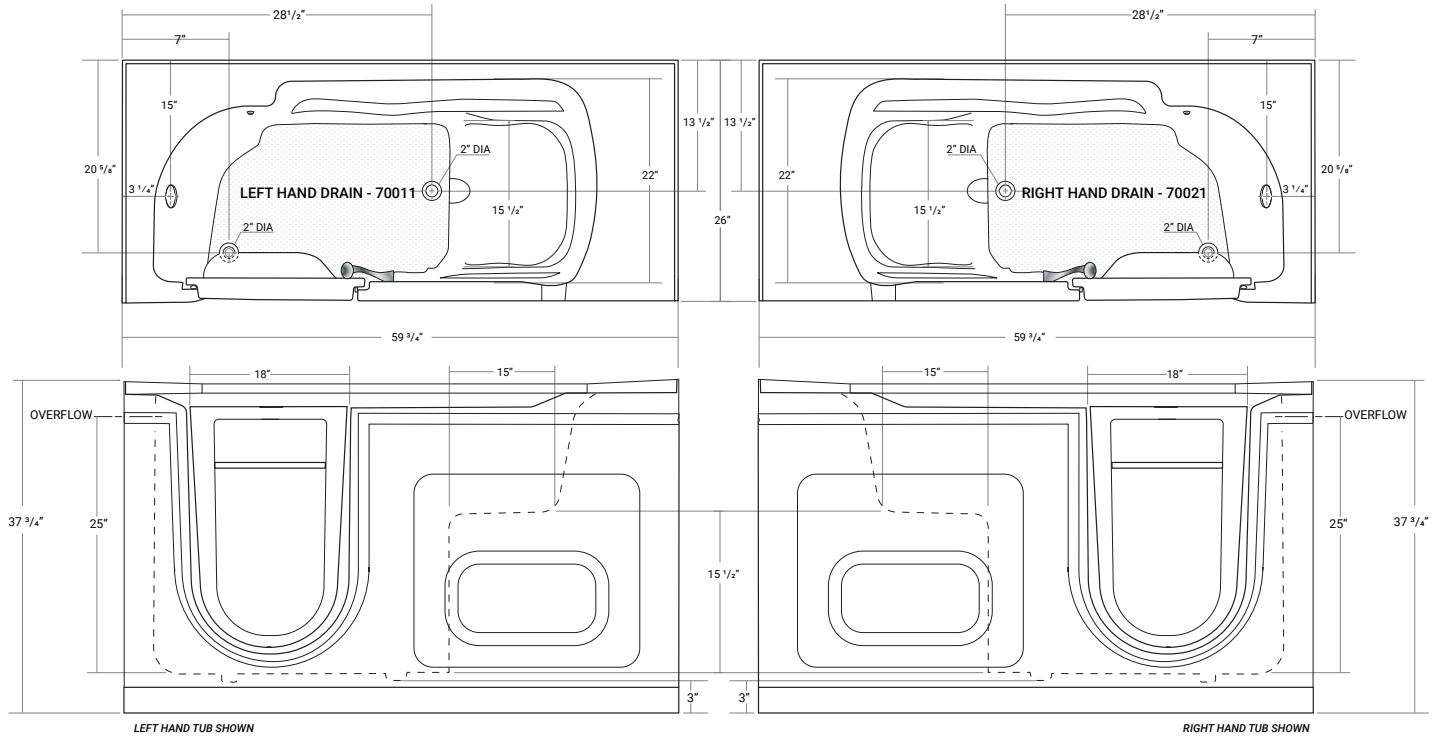

Acritec Industries Corp.

27049 Gloucester Way
Langley, B.C. V4W 3Y3

Tel: 604.607.0856

Fax: 604.607.0857

Email: info@acritec.com

Website: www.acritec.com

In keeping with our policy of continuing product improvement, Acritec Industries Corp. reserves the right to change product specifications without notice.

Important

*While we strive to provide accurate measurements for our customers, sometimes mistakes happen. Our goal is to help things run smoothly from shipment to installation, so if you notice any errors in our spec sheets, please let us know.

Our products are handmade & hand finished so you can expect a tolerance of $\pm \frac{1}{4}$ " on all measurements. We strongly recommend waiting until your ordered product is on-site before attempting any rough-in carpentry or plumbing.

If you want to verify any of our measurements, please feel free to call or email us.

*Drawings are not to scale

